

100

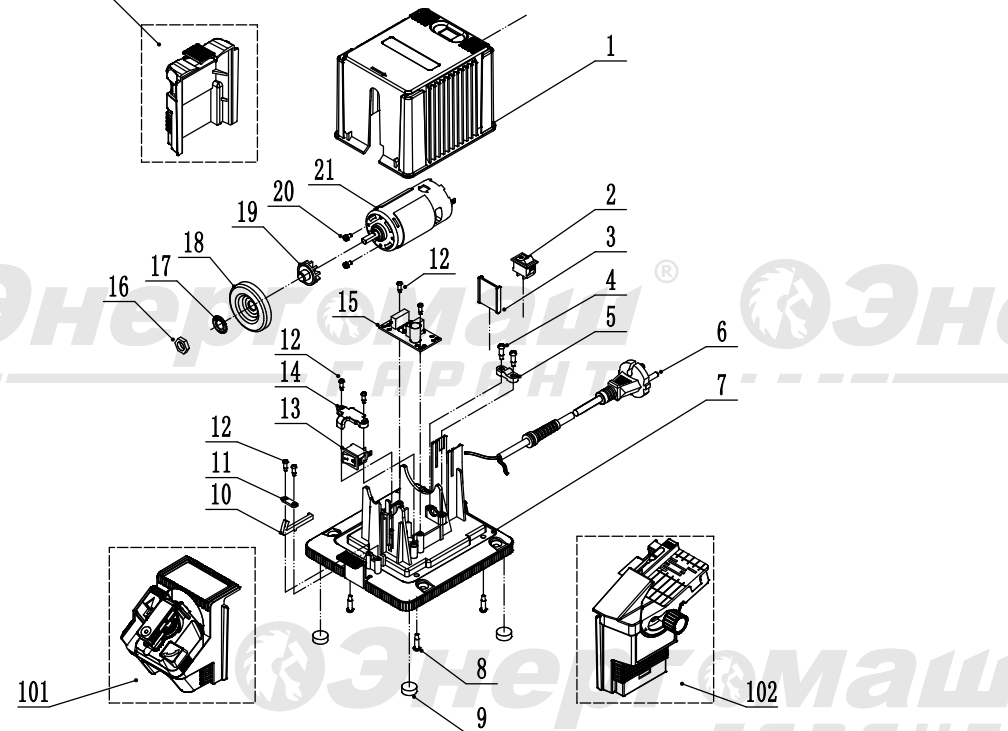

TC1-100M

NO.	DESCRIPTION	NO.	DESCRIPTION
1	Top Housing	100	Scissor sharpener holder
2	Switch	101	drill bits sharpener holder
3	Baffle plate	102	blade sharpener holder
4	Screw	100-1	Fixing shelf for Scissors
5	Platen	101-1	Locking Lump
6	Cord	101-2	Gripping Lump
7	Base	101-3	Locknut
8	Screw	101-4	right-chuck
9	Pilable foot	101-5	Counter Card
10	Botton	101-6	Fixing sheet
11	Platen	101-7	Backing iron sheet
12	Screw	101-8	Supporting chuck for drill
13	Auxiliary Switch	101-9	Fixing Chuck for Drill
14	Pressing plate	101-10	Screw
15	PCB	102-1	Screw
16	Nut	102-2	Plane Blade Holder
17	Sign for Rotational Direction	102-3	Move Instruction
18	Grinding Wheel	102-4	Supporting Shelf
19	Wheel Valve	102-5	Angle conditioner
20	Screw	102-6	Locknut
21	Motor	102-7	Protective Guard
		102-8	Magnet Card
		102-9	Magnet

TS1-100M-EX-20200921

